



QCS3 SERIES HIGH VOLUME BUN CONVEYOR TOASTER Model QCS3-1400BH

QCS Features/Benefits:

- ★ Holman's forced convection system keeps the toaster cool to the touch and extends the life of critical components. The forced convection increases productivity by circulating pre-heated air into toasting chamber.
- ★ Quartz infrared heaters provide faster, more consistent heating than traditional heating elements.
- ★ High volume compact toaster - requires only 18-1/2" of counter space and the forced convection system allows the unit to be placed against a wall. Other toasters have louvers requiring additional counter space.
- ★ A high performance unit, the QCS3-1400BH produces an industry leading 1400 bun halves per hour.
- ★ Easy to use control panel takes the guesswork out of temperature and speed control settings.
- ★ Variable speed and top and bottom heat controls for perfect color and texture of buns.
- ★ Energy efficient operation with power saver switch reduces electricity consumption by 75%. And our quartz heaters return to full power in seconds vs. minutes for metal-sheathed elements.
- ★ Extended conveyor belt for easy loading and higher production.
- ★ Safe load up area with full width coated front burn guard and cool to the touch exterior.
- ★ "Smart" crumb tray keeps the breadcrumbs from falling under the toaster.
- ★ Heated holding area to keep toast at the perfect temperature.
- ★ Hi-limit switch prevents toaster from overheating, protecting critical component parts.
- ★ 24 hours 7 days a week technical support by Star technicians.



QCS3-1400BH

Applications:

Holman's QCS3-1400BH is a high performance bun toaster that will keep pace with a hungry crowd - all day long. Whether you are a high volume school cafeteria or a high volume restaurant, Holman's QCS3-1400BH will provide high capacity and consistent toasting.

Quality Construction:

Stainless steel construction for long lasting durability. Heavy-duty motor, drive chain and conveyor speed control for superior reliability. Conveyor belt tension system for smooth and quiet operation. High performance Quartz Infrared Heaters for superior toasting performance and reliability. Toasters are furnished with 1" adjustable legs and 4' cord.

Warranty:

Holman's conveyor toasters are covered by a one-year parts and labor warranty.



QCS3 Conveyor Toaster



QCS3 SERIES

HIGH VOLUME BUN CONVEYOR TOASTER

Model QCS3-1400BH

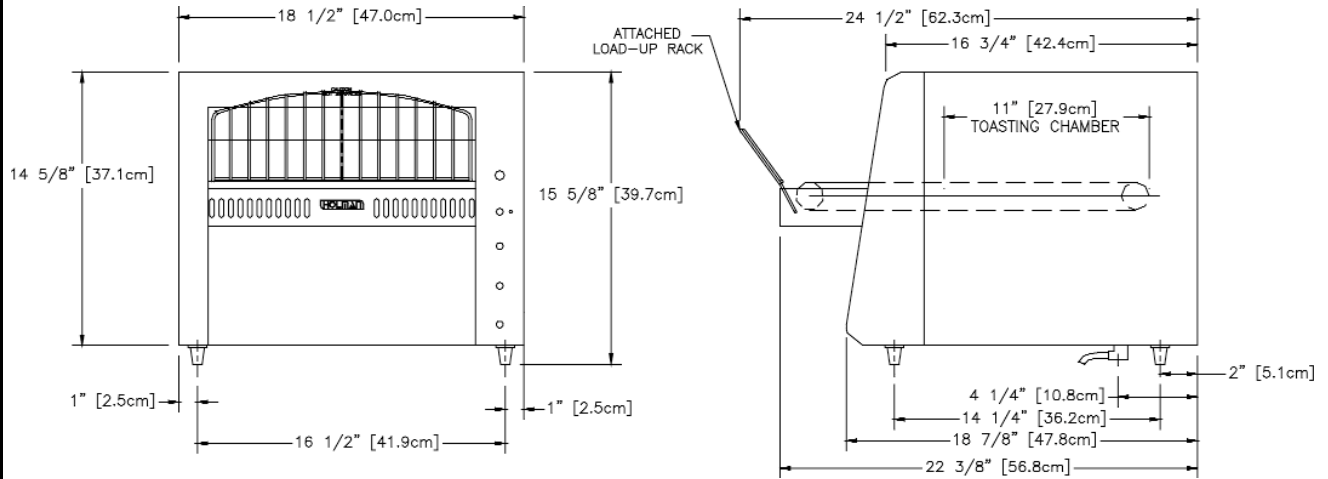

Performance Data

| Model No. | Production Capacity | Product Opening |
|-------------|--------------------------------|-----------------|
| QCS3-1400BH | Up to 1400 bun halves per hour | 3" |

Specifications

| Model No. | Dimensions | | | Shipping Weight lbs. (kg) | Shipping Carton | | |
|-------------|-------------------------|-------------------------|--------------------------|---------------------------------|-------------------------|-------------------------|--------------------------|
| | Width Inches (cm) | Depth Inches (cm) | Height Inches (cm) | | Width Inches (cm) | Depth Inches (cm) | Height Inches (cm) |
| QCS3-1400BH | 18-1/2" (47.0) | 22-3/8" (56.8) | 15-5/8" (39.7) | 68 (149.6) | 22-3/4" (57.7) | 19-3/4" (50.1) | 25-3/8" (64.4) |

Electrical Data

| Model No. | Volts | HZ 1 Phase | Amps | Watts | Heating Elements ¹ | | Plug |
|-------------|-------|------------|------|-------|-------------------------------|------------|---------------------------------|
| | | | | | Above Belt | Below Belt | |
| QCS3-1400BH | 208 | 60 | 15.8 | 3400 | 4 | 2 | 6-30P |
| | 240 | 60 | 13.8 | 3400 | 4 | 2 | 6-30P |
| QCS3-1400BH | 220 | 50 | 15.0 | 3400 | 4 | 2 | Not supplied with cord and plug |
| | 240 | 50 | 13.8 | 3400 | 4 | 2 | Not supplied with cord and plug |

¹Can be supplied with metal sheathed heaters (208V 16.3 amps & 240V 14.2 amps), however production will be reduced.

Typical Specifications

High volume bun conveyor toasters are constructed of corrosion resistant stainless steel. Supplied with heavy-duty motor, and drive chain and fast heat up quartz infrared heaters. A conveyor belt tension system is supplied for a smooth, quiet operation. Units are supplied with variable speed control, top and bottom heat control, power saver and high limit switch. Extended conveyor belt, crumb tray, heated holding area and full width burn guard are standard. Unit has a one-piece cover for easy access with 1" adjustable legs and a 4' cord. Units are listed with UL, CUL and are UL certified to NSF4. CE Approved. Printed in the U.S.A.

Due to periodic changes in designs, methods, procedures, policies and regulations, the specifications contained in this sheet are subject to change without notice. While Star Manufacturing exercises good faith efforts to provide information that is accurate, we are not responsible for errors or omissions in information provided or conclusions reached as a result of using the specifications. By using the information provided, the user assumes all risks in connection with such use.

Star Manufacturing International, Inc. - 10 Sunnen Drive - P.O. Box 430129 - St. Louis, MO 63143-3800

Phone: (800) 264-7827 - FAX: (800) 264-6666 - www.star-mfg.com