

Project Name: _____ AIA#: _____

Model #: _____ Location: _____

SIS#: _____ Item #: _____ Quantity: _____



Food Warming Lamp

Chefmate® Countertop Equipment

Model

WL2 Countertop Food Warming Lamp



& NSF 4 Sanitation approved

GLOBE FOOD EQUIPMENT COMPANY

Food Warming Lamp

WL2

Standard Accessories

- Includes two R40, (250W) bulbs

Applications

- Designed to keep food products warm for serving

Warranty

- One-year parts and labor

Standard Features

- 500W; Two (250W) dome lamps and two (R40) bulbs included for constant warming (Light bulbs are shatter resistant)
- High-temp ceramic bulb sockets
- 5 adjustable heights
- ON/OFF switch conveniently located on post
- Sturdy, anodized aluminum construction with brushed finish
- Freestanding countertop design with non-skid, protective counter feet
- Stores easily
- 22"W x 14"D x 21"H
- 6-foot power cord



Globe Food Equipment Company

Approved by: _____ Date: _____



Food Warming Lamp

WL2

Specifications

Electric: Attached 6-foot flexible, three-wire cord with ground plug (NEMA 5-15). 120V/60Hz/500W

Construction: Aluminum

Finish: Brushed aluminum

On/Off Switch: Easy-to-use and access power on/off switch.

Consistent Warming: 500W;
Two (250W) screw type bulbs with shatter contained coating.

Standard Equipment: Standard equipment includes: warming lamp with two attached domes, adjusting screw for height selection, and two R40, (250W) light bulbs.

Acceptable Replacement Bulbs: R40, (250W) light bulbs

Dimensions:
Foot Print = 22" x 21"
(55.9 cm x 53.5 cm)
Overall Length = 22" (55.9 cm)
Overall Width = 21" (53.5 cm)
Overall Height = 14" (35.6 cm)

Shipping Information:
Net Weight: 7.8 lbs (3.5 kg)
Shipping Weight: 8 lbs (3.7 kg)

Shipping Dimensions:
14"W x 20.9"D x 20.5"H
(35.5 cm x 53 cm x 52 cm)

Cartons are reinforced for shipping. The weight and dimensions of this reinforced carton are included above and may vary from shipment to shipment.

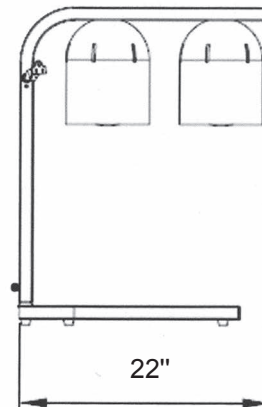
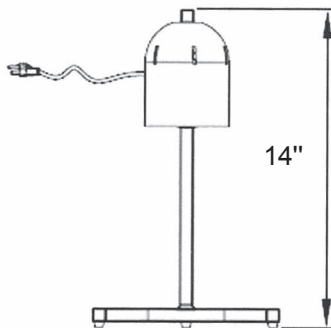

Plug Type - NEMA 5-15

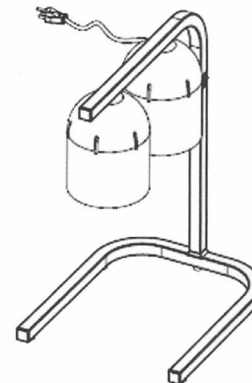
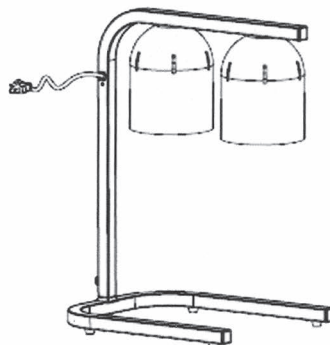
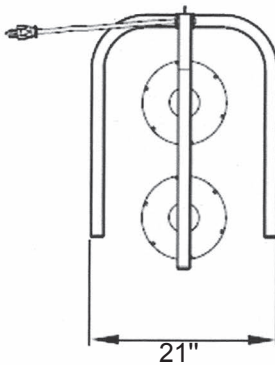

Globe Food Equipment Company